

Conestoga District Boy Scout

Klondike Derby

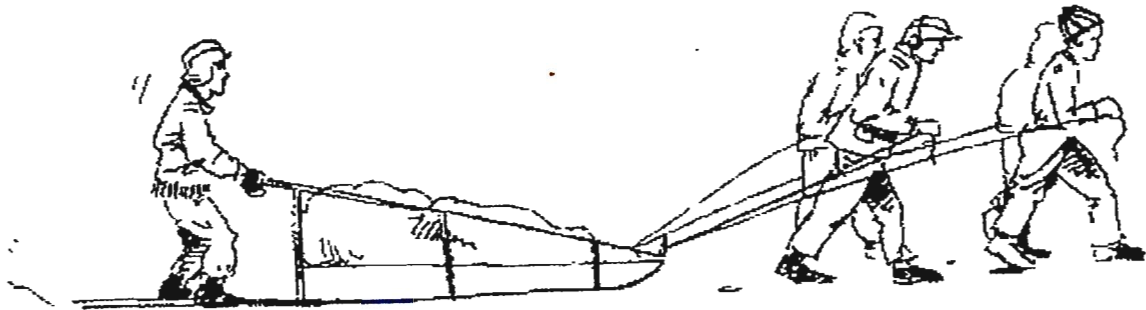

February 6, 2010

*PA had lists
by 2/3/10 by email to
GABM@SHEDIVERSION.NET*

Trax Farm
Finleyville, PA.

Camporee Camp Rules

1. All Scouts and Leaders must act in accordance with the Scout Oath and Law at all times.
2. All rules in the “Guide to Safe Scouting” must be adhered to at all times.
3. Scouts must use the buddy system at all times they are outside of their campsite.
4. All medications must be administered, per the Medical Information Sheet by the Unit Leader.
5. **All injuries must** be reported to the Camporee Health Officer, so he/she may log them.
Minor injuries can be handled by the unit and reported later.
6. The Health Officer must be notified of all **Serious Injuries and Illnesses Immediately**.
7. The Health Officer must be made aware of any Scout or Adult with a medical condition that may need treatment. This will allow the Health Officer to have an idea of any potential medical emergencies. This information will be kept Strictly Confidential and will be provided to the EMS, if an emergency should arise. See the attached sheet to be brought with the unit and turned in at the time of check-in.
8. Only Registered Boy Scouts or Venturers and their Leaders or Parents will be permitted to Camp Overnight.
9. Coffee / Bug juice will be provided for Adult Scout Leaders.
10. Close-toed Shoes or Boots must be worn at all times outside of tents.
11. Remember, No Flames are allowed in tents. This includes propane lanterns, heaters, etc.
12. Climbing of trees is prohibited. Leave all live trees alone.
13. Lights out means quiet (Youth and Adults).
14. Use of Offensive Language is prohibited.
15. Possession or use of alcohol or illegal drugs is strictly prohibited. Any violations of this rule will be dealt with severely.
16. **Each unit must maintain “Two Deep Leadership” at all times.**
17. Adult smoking will be allowed **only** in the designated areas (out of the view of all Scouts).
18. The Staff may suspend all open fires based on safety concerns or weather conditions.
19. All Vehicles **MUST** be in designated Parking Areas (Trailers may be in the Campsite).
20. **Show Scout Spirit Throughout the Weekend**

Cold Weather Camping

COLD WEATHER COMFORT & SAFETY

Cold weather camping as defined by BSA is "camping in weather where the average daily temperature is below 50 degrees Fahrenheit and conditions are cold, wet or windy."

The most important thing to remember about cold weather camping is to **KEEP DRY**. Moisture will reduce the insulating properties of almost everything. To keep yourself warm, remember the word **COLD**.

- C** keep yourself and your clothes **Clean**.
- O** avoid **Overheating**.
- L** wear clothes Loose and in **Layers**.
- D** keep **Dry**.

The hints listed below are in a random manner. There is no order of importance to the list, just some suggestions that have proven true for me over the years.

CLOTHING

1. Layer your clothing. Wear several layers of lighter clothing instead of one heavy layer. This way you can better regulate the amount of insulation. If you get warm you can take layers off and add some more clothing layers if you get cold.
2. Keep yourself dry, both from the weather and perspiration.
3. Wear loose fitting clothing, to optimize insulation.
4. Remember when buying clothes for cold weather that wool retains most of its insulation properties when wet, while cotton loses most of its.
5. There are also excellent manmade fibers and insulations that retain their insulation properties as good as or better than wool. Other benefits include light weight, wide design options & wind-blocking.
6. Remember your rain gear is water proof and will not allow perspiration to exit. During rainy weather change your clothing several times a day.
7. Athletic shoes and nylon hiking boots do not provide enough insulation. You should wear either mukluks, water-proofed leather hiking boots, rubber overshoes or rubberized boots.
8. Waterproof your leather hiking boots with the appropriate commercial treatment. Be sure to use only silicon-based products on leathers which require it. Check the care tag that came with the boots.
9. If you choose to wear rubberized boots, remember they do not allow for ventilation, therefore you will need to change your socks several times a day. Also you may want to get some felt inserts for insulation.
10. Wear a pair of cotton and a pair of wool socks to increase insulation and take the perspiration away from your feet.
11. Pull trouser legs over top of shoes to keep out snow. You may want to use nylon gaiters (leggings), or tie or tape them to make sure of the seal.
12. Wear mittens instead of fingered gloves when you do not need independent use of your fingers. This will allow the fingers to help keep each other warm.
13. Use a pair of socks to cover hands if mittens get wet.
14. Wear a stocking cap or other warm hat. One that covers the ears and neck area is particularly effective. Remember, most heat loss is through the head. Wearing a warm hat warms the rest of your body, too.
15. Wear a scarf to reduce heat loss around the neck. Use a "ski mask" or scarf over your face for protection from the cold and wind.
16. In an emergency use your neckerchief to cover your ears.
17. If you need a fire to keep you warm you are not dressed properly. If the heat can get to your body, so can the cold.
18. Paper is a good insulator and can be wrapped around the body (under your clothes) to add insulation.



Boy Scout Klondike Derby



February 6, 2010
Trax Farm

KLONDIKE DERBY REGISTRATION FORM

The Conestoga District is holding this year's 2010 Klondike Derby at Trax Farms on Route 88 in Finleyville Pa. **The cost is \$10 per person the deadline for registration is January 29th.** All money needs to be at **Flag Plaza** by 5pm. on this date.

Registration Details

Troop # _____

Scouts _____

Adults _____

Total Troop Participants _____

Total Payment(@ \$10 each) _____ (checks to GPC-BSA)

For planning purposes we need each Troop to complete this registration form and do the below actions.

1. Make a copy of this form.
(sent or bring form with payment to)
Greater Pittsburgh Council (GPC-BSA)
1275 Bedford Ave.
Pittsburgh , Pa. 15219
Attention: Jake Kraus

2. Bring 1 copy to the event with you.

Klondike Derby Planning Details

When : February 6, 2010 8:00am-4:00pm

Where: Trax Farm Route 88 Finleyville Pa.

Cost: \$10 per person (*includes Lunch by T-228 and Hot Cocoa and Coffee during the day*)

Camping: Available (*troops wishing to camp overnight must make prior arrangements with Trax Farms by contacting Chuck Trax Jr. @412-266-5915*)

Supplies: Klondike Sled(*must be capable of transporting 1 Scout*) pulled by no more than 4 scouts and 1 pusher

Fire Starter (no liquid fuels)	Drinking water	Lashing rope(50ft)
Compass(1 per scout if possible)	Scout Staves(2)	Troop /Patrol flag
Clipboard&paper ,Pencils	Tarp	First Aid kit & supplies
Work Gloves	Rescue rope	Troop/Patrol Roster
Troop/Patrol yell		

Proposed Stations : Sled Judging (*includes supplies*)

Fire Starting T-65

Buck Sawing T-28

Stretcher Obstacle course T-4

Knots T-228

Gum drop tower T-23

Unknown T-366

First Aid Sled race T-4 ,T-23, T-28, T-65, T-228, T-366

Need helmet for sled rider

Klondike Derby Schedule

8:00am-8:30am	Registration (Green House)
8:45am	Opening Flag Ceremony
9:00	Sled Judging
9:30	Station One
10:15	Station Two
11:00	Station Three
11:45-1:00	Lunch (Green House)
1:15	Station Four
2:00	Station Five
2:45	Station Six
3:00	First Aid Sled Challenge(timed event)
3:45	Awards & Closing
4:00	Departure

*Scout uniforms
are not required*

THE OFFICIAL CONESTOGA DISTRICT

WHILE YOUR OWN DESIGN WILL BE ACCEPTED, THIS DIAGRAM SHOWS AN AUTHENTIC SLEDGE. YOU MAY PAINT THEM BRIGHT COLORS PUT VARNISH OR WAX THE BOTTOM OF THE RUNNERS. ACCESSORIES MAY BE ADDED, CANVAS SNOW GAURDS FOR THE FRONT AND SIDES. USE BOLTS OR SCREWS INSTEAD OF NAILS - DRILL FIRST TO AVOID SPLITTING. MAKE A TOWING BRIDLE OF ROPE, ABOUT 20 FEET LONG.

BILL OF MATERIALS

PT.	QTY.	
1	2	4" X 1/2" X 66" - Runner
2	6	1" x 1" X 18" - Cross Support
3	4	1/2" X 4" X 5" - Floor Cover
4	8	1" X 2" X 6" - Upright Supports
5	2	1" X 2" X 40" - Rear Upright
6	2	1" X 2" X 30 1/2" - 2nd. Rear Upright
7	2	1" X 2" X 21 1/2" - 2nd. Front Upright
8	2	1" X 2" X 12" - Front Support
9	2	1/2" X 2" X 6" - Hand Rail
10	1	1/2" X 2" X 30" - Front Curved Gaurd
11	1	2" X 2" X 18" - Rear Hand Rail
12	1	1/2" X 10" X 18" - Packet Holder
13	2	1" X 2" X to suit - Bracing

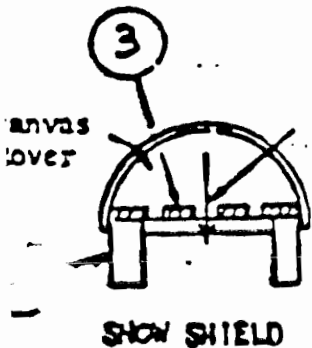
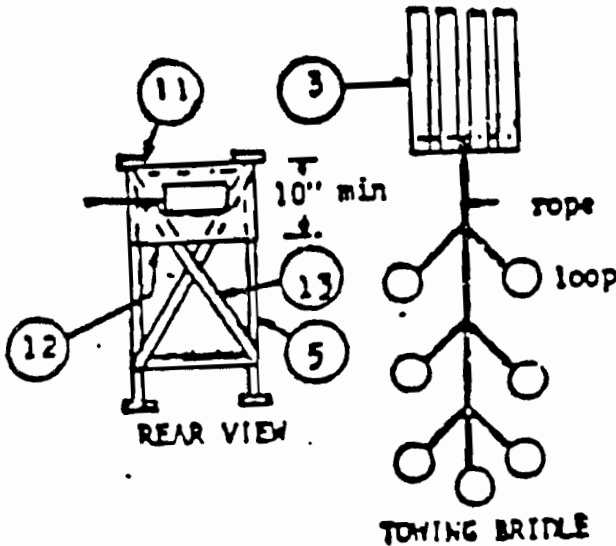
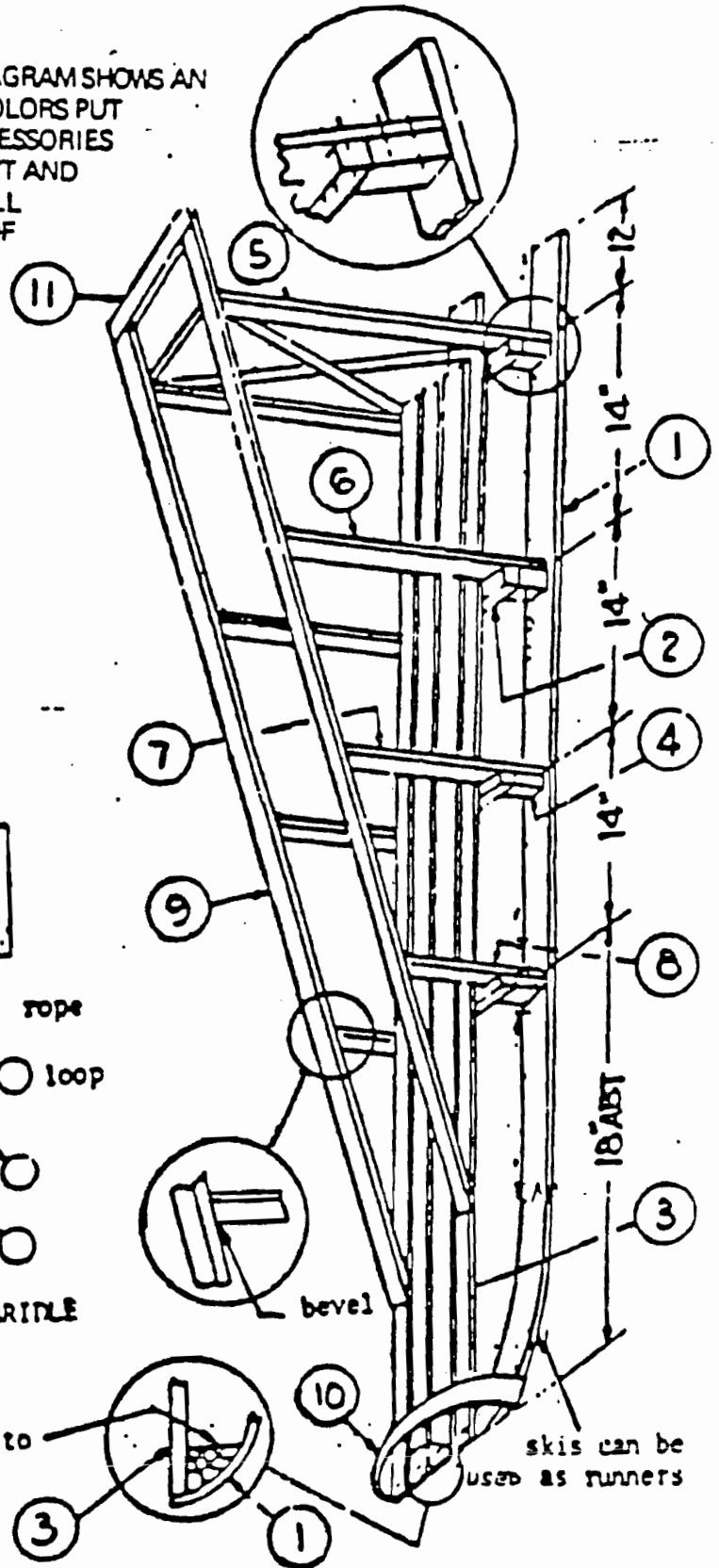

drill 1/2" hole for towing bridle

shape to suit

skis can be used as runners

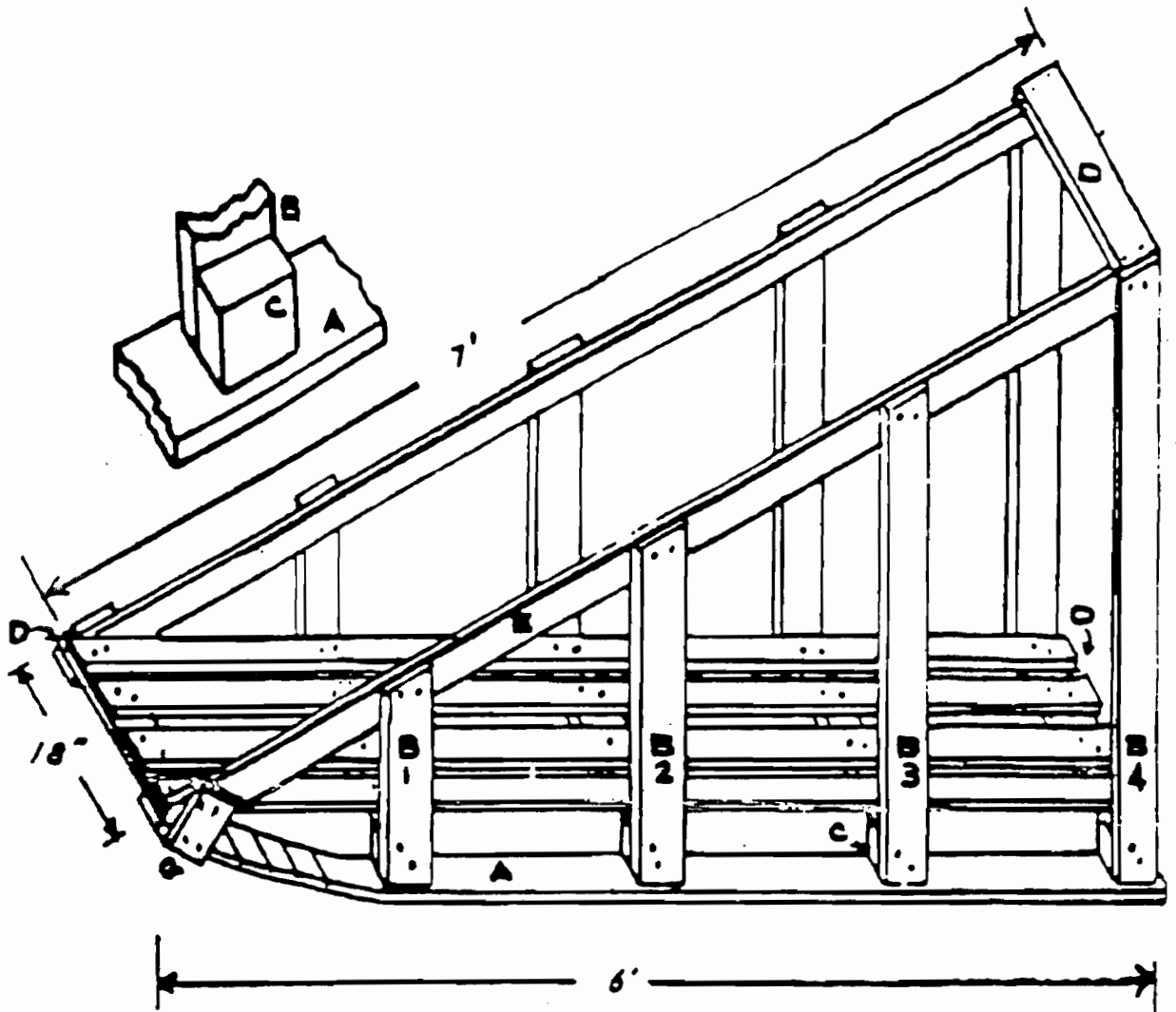

BILL OF MATERIAL

Part	Key	No. Pieces	Dimensions
Runners	A	2	1" x 4" x 6'
Uprights	B4	2	1" x 4" x 3'6"
	B3	2	1" x 4" x 2'8"
	B2	2	1" x 4" x 1'9"
	B1	2	1" x 4" x 10"
Upright supports	C	8	2" x 4" x 4"
Cross supports	D	6	1" x 4" x 1'6"
Floor Strips	E	4	1" x 4" x 6'
Hand rails	F	2	1" x 2" x 7'
Front supports	G	2	1" x 4" x 6"